

**GROVE**

# TMS 865



**HYDRAULIC  
CRANES**

Patented Grove feature

**65**

TON CAPACITY

**60**

TONS METRIC

**HYDRAULIC  
CRANE with  
TRAPEZOIDAL<sup>†</sup>  
BOOM**

CONSTANT IMPROVEMENT AND ENGINEERING PROGRESS MAKE IT NECESSARY THAT WE RESERVE THE RIGHT TO MAKE SPECIFICATION, EQUIPMENT AND PRICE CHANGES WITHOUT NOTICE. ILLUSTRATIONS SHOWN MAY INCLUDE OPTIONAL EQUIPMENT AND ACCESSORIES AND MAY NOT INCLUDE ALL STANDARDS AND EQUIPMENT. OPTIONAL EQUIPMENT IS DESIGNATED BY \* IN SPECIFICATIONS FOLDER.

# 180' OF ON-BOARD TIP HEIGHT

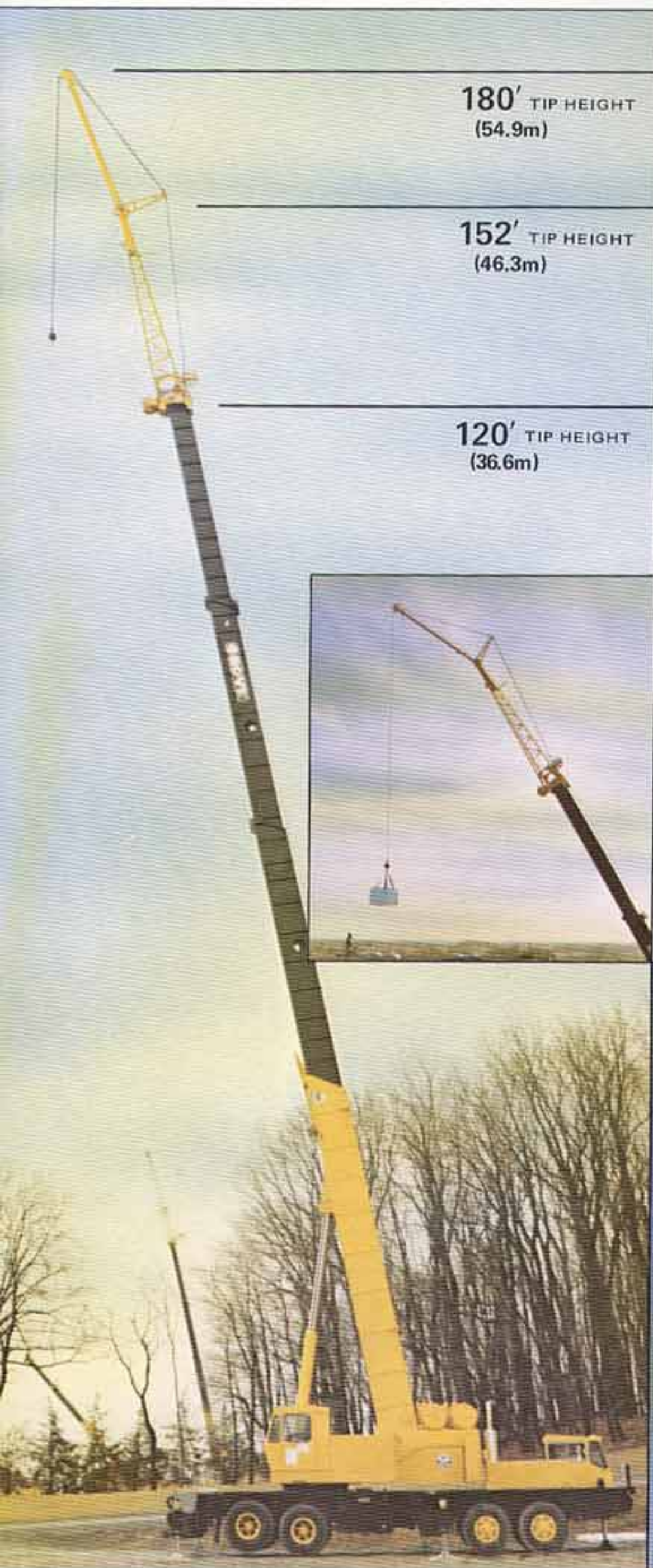

180' TIP HEIGHT  
(54.9m)

152' TIP HEIGHT  
(46.3m)

120' TIP HEIGHT  
(36.6m)

## QUICKLY AVAILABLE... SUPERIOR CAPACITY

**THE GROVE TRAPEZOIDAL† BOOM** is the proven performer among high capacity long reach booms. It is a major engineering accomplishment in telescoping boom design and provides the optimum strength-to-weight ratio for hydraulic crane operation. The superior strength and rigidity are directly attributable to the Trapezoidal design and the use of very high strength steels. This permits a deeper, wider and lighter boom with greater resistance to lateral and vertical deflection.

**FULL POWER 4-SECTION BOOM\*** optional boom provides quick set-up. The standard 4-section boom is power-pinned.

## UP TO 30° OFFSET

The standard 32' (9.7 m) "Swingaway" plus the optional "A" frame jib provide a total "on-board" tip height of 180' (54.9 m). Both the "Swingaway" and the "A" frame jib are independently stowable alongside the boom base section. The jib is offset 5°, 17° or 30° to give you maximum up-and-over reach.

## 206'(61.5 m) TIP HEIGHT

By combining 14' (4.3 m) lattice inserts with the "Swingaway" section, jibs of 46' (14 m), 60' (18.3 m), 74' (22.6 m) and 88' (26.8 m) can be assembled providing a top tip height of 206' (61.5 m). Lattice jib is offsettable from 5° to 30°.

†Patented Grove feature  
\*Optional equipment

# TMS865

## SPECIFICATIONS



**GROVE MANUFACTURING COMPANY**

Distributor: Walter Kidde & Company, Inc.

**KIDDE**

SHADY GROVE, PA. 17215

## CARRIER ENGINE SPECIFICATIONS

MAKE & MODEL	Cummins NTC290	*GM 6-71T	*Caterpillar 3306TA
TYPE	6 Cylinder	6 Cylinder	6 Cylinder
BORE & STROKE	5.5 in. x 6 in. (140mm x 152mm)	4.25 in. x 5 in. (108mm x 127mm)	4.75 in. x 6 in. (121mm x 152mm)
DISPLACEMENT	855 cu. in. (14 013cm <sup>3</sup> )	426 cu. in. (6982cm <sup>3</sup> )	638 cu. in. (10 454cm <sup>3</sup> )
HORSEPOWER (NET)	268 at 2100 RPM	251 at 2100 RPM	249 at 2200 RPM
GOVERNED RPM	2100	2100	2200
TORQUE (NET)	885 lbs. ft. (118kg.m) @ 1300 RPM	758 lbs. ft. (104kg.m) @ 1400 RPM	739 lbs. ft. (102kg.m) @ 1400 RPM
ELECTRICAL SYSTEM	12 volts	12 volts	12 volts
STARTING SYSTEM	24 volts	24 volts	24 volts
COMBUSTION SYSTEM	4 cycle turbocharged	2 cycle turbocharged	4 cycle turbocharged
COOLING SYSTEM	Liquid	Liquid	Liquid
ALTERNATOR	12 Volt 90 Amp	12 Volt 90 Amp	12 Volt 90 Amp
BATTERY	•(4) 12 volt 475 CCA @ 0° F	•(4) 12 volt 475 CCA @ 0° F	•(4) 12 volt 475 CCA @ 0° F
AIR CLEANER	2 stage dry type	2 stage dry type	2 stage dry type
AIR COMPRESSOR	13.2 CFM	12 CFM	12 CFM

•CCA – Cold cranking amperage per battery.

\*Denotes optional equipment

NOTES: (1) Jacobs engine brake (GM & Cummins engines only) is optional.

(2) Engine performance ratings are to SAE J816B. Performance will be reduced when operating at higher elevations.

Following are approximate reductions for operation at 10,000 ft. (3048m) above sea level: Cummins – 0%; GM – 3.5%; Cat. – 14.5%.

### SPEED AND GRADEABILITY WITH FULLER RT9509A TRANSMISSION

ENGINE	Speed Ranges @ Max. Governed RPM		% of Gradeability @ Max. Torque	
	Aux. Low	Aux. Direct	Aux. Low	Aux. Direct
Cummins NTC290	2.0 to 23.6 MPH (3 to 38 km/h)	4.1 to 48.1 MPH (6 to 77 km/h)	56.95 to 3.44	27.15 to .92
*Caterpillar 3306TA	2.1 to 24.8 MPH (3 to 40 km/h)	4.3 to 50.4 MPH (7 to 81 km/h)	47.21 to 2.62	22.38 to .52
*GM6-71T	2.0 to 23.6 MPH (3 to 38 km/h)	4.1 to 48.1 MPH (6 to 77 km/h)	49.22 to 2.79	23.36 to .6

### SPEED AND GRADEABILITY WITH \*ALLISON HT750CRD AUTOMATIC TRANSMISSION

ENGINE	Speed Ranges @ Max. Governed RPM		% of Gradeability @ Stall	
	Aux. Low	Aux. Direct	Aux. Low	Aux. Direct
Cummins NTC290	6.4 to 23.6 MPH (10 to 38 km/h)	13.0 to 48.1 MPH (21 to 77 km/h)	35.8	17.1
*Caterpillar 3306TA	6.7 to 24.8 MPH (11 to 40 km/h)	13.7 to 50.4 MPH (22 to 81 km/h)	32.6	15.5
*GM6-71T	6.4 to 23.6 MPH (10 to 38 km/h)	13.0 to 48.1 MPH (21 to 77 km/h)	31.2	14.8

NOTE: Performance based on 98,500 lbs. GVW (44 680kg) and standard SAE engine rating conditions using standard tires, transmissions and axles.

Performance data may vary plus or minus 10% due to variations in engine performance and vehicle weights.

Machines should be operated within the limits of crankcase design (Cummins – 15°, GM and Caterpillar – 20°).

Gradeability values above 45% are theoretical.

\*Denotes optional equipment



## CARRIER SPECIFICATIONS

**OUTRIGGERS** – Hydraulic, double-box, telescoping beam outriggers, integral welded boxes, removable beams, vertical 6 in. (152mm) bore x 17 in. (432mm) stroke jack cylinders with integral holding valves and 30½ in. (775mm) diameter removable stowable steel floats. Beams extend to 23 ft. (7.0m) centerline to centerline and retract to within 11 ft. (3.4m) overall width by 3 in. (76mm) bore double-acting cylinders. Controls and sight leveling bubble located in superstructure cab and each side of carrier. Powered by carrier engine. In addition to the standard integral holding valve and for added security, the exclusive Grove \*spin-lock is offered, which permits the outrigger vertical jack to be mechanically locked in any position throughout its stroke.

**FRONT END STABILIZER** – A fifth hydraulic vertical jack cylinder with integral holding valve is mounted to the front frame section of the chassis to permit 360° lifting capabilities. The 24 in. (610mm) diameter steel float is easily removed for highway travel. Individual controls for fifth outrigger cylinder conveniently located in superstructure cab and each side of carrier frame.

**FRAME** – High strength steel, all-welded construction with triple-box type design and integral welded outrigger boxes.

**STEERING GEAR** – Ross cam and lever type with Garrison hydraulic power assist.

**CLUTCH** – Lipe Rollway 14 in. (356mm), two plate, dry disc (with Roadranger transmission only).

**TRANSMISSION** – Fuller Roadranger RT9509A – 9 speeds forward, 2 reverse with Fuller AT1202, 2-speed auxiliary.  
\*Allison HT750CRD – 5 speeds forward, 1 reverse fully automatic transmission with Fuller AT1202 2-speed auxiliary.

**UNIVERSAL JOINTS** – Needle bearing type.

**AXLES** – Front: (2) Rockwell tubular steering FL-951, 100 in. (254mm) track, 44,000 lbs. (19 958kg) capacity.  
Rear: Rockwell SW 170 tandem, 100 in. (254mm) track, 70,000 lbs. (31 752kg) capacity with interaxle differential.

**SUSPENSION** – Front: Reyco 21-B spring-mounted tandem, 44,000 lbs. (19 958kg) capacity.  
Rear: Hendrickson T-900 tandem – axle equalizing beam with solid steel saddles, 70,000 lbs. (31 752kg) capacity.

**FUEL TANK** – Single 100 gallons (379 liters) mounted on left side of frame.

**TIRES** – Front: 18:00 x 22.5-18PR highway tread tubeless.  
Rear: 12:00 x 24-16PR highway tread tube-type. Optional are Michelin 14:00R20-22PR (G-20X) radial tube-type front or rear, Michelin 12:00R20-18PR rear, 14:00 x 20-20PR bias front or rear.

**RIMS** – Front: demountable 22.5 x 13 (572mm x 330mm).  
Rear: demountable 24 x 8.5 (610mm x 216mm). Optional 10 x 20 (254mm x 508mm) with 14:00 x 20 size tires.

**WHEELS** – Steel spoke (6 spokes) front and rear.

**\*TIRE INFLATION KIT** – Quick connect air outlet located at midpoint on either side of carrier. Includes dual foot air chuck and 25 ft. (7.6m) cooled nylon tubing.

**BRAKES** – Full air on all wheels.  
Front: 15 in. x 6 in. (381mm x 152mm)  
Rear: 16½ in. x 7 in. (419mm x 178mm)  
Total lining area: 1,672 in.<sup>2</sup> (10 788cm<sup>2</sup>)  
Air dryer provided to preclude system-damaging moisture accumulation.

**PARKING BRAKES** – Spring-set, air-released chambers on both rear axles with manual emergency feature.

**ELECTRICAL SYSTEM** – 12-volt lighting, 24-volt starting. Federal safety standard lights and reflectors.

**CAB** – One-man, left hand drive, all-steel construction, with acoustical treatment, tinted safety glass throughout, electric wiper and washer, door and window locks, Bostrom "T" bar seat with seat belt, hot water heater, defroster fan, dual West Coast mirrors, domelight, instrument lights, electric horn, traffic hazard warning switch (4-way flashers), complete instrumentation and driving controls, 2¾ lb. (1.25kg), dry type fire extinguisher.

**CAB INSTRUMENTATION** – (International Type) – Engine oil-pressure gauge, speedometer, dual air-pressure gauge, fuel-level gauge, engine water-temperature gauge, voltmeter, tachometer, low air-pressure audio-visual warning device, high-beam indicator, hourmeter (10,000 HR.).

**MISCELLANEOUS STANDARD EQUIPMENT** – Wheel nut wrench and handle, channel-type front bumper, two front and rear towing loops, front and rear fenders, full width decking, ether injection starting aid (less canister), mud flaps, hookblock storage trough, maintenance-free batteries, backup light, air cleaner service indicator.

**MISCELLANEOUS OPTIONAL EQUIPMENT** – Sling box on left side of frame, lifting lugs and tie down attachments, trailer air and electrical disconnect, rear mounted pintle hook, engine block heater, spare tire and wheel mounting bracket, electronic back-up alarm.

# DIMENSIONS

45' (13.7m)

TURNING RADIUS ~~39' 11" (12166)~~

GROUND CLEARANCE 11 5/8" (3359)

TAIL SWING 14' 2" (4267)

Note: Dimensions in parenthesis ( ) are millimeters (mm)

Meets requirements of P.C.S.A. Standard No. 2

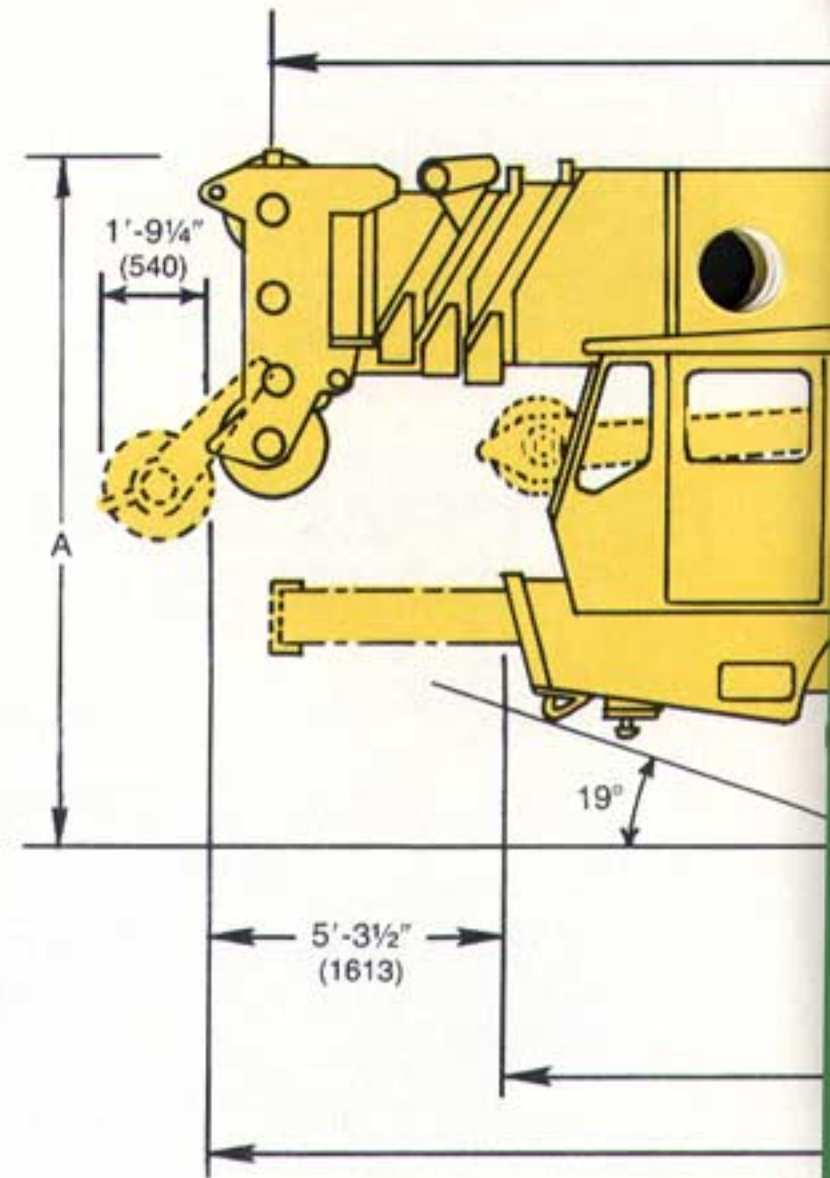
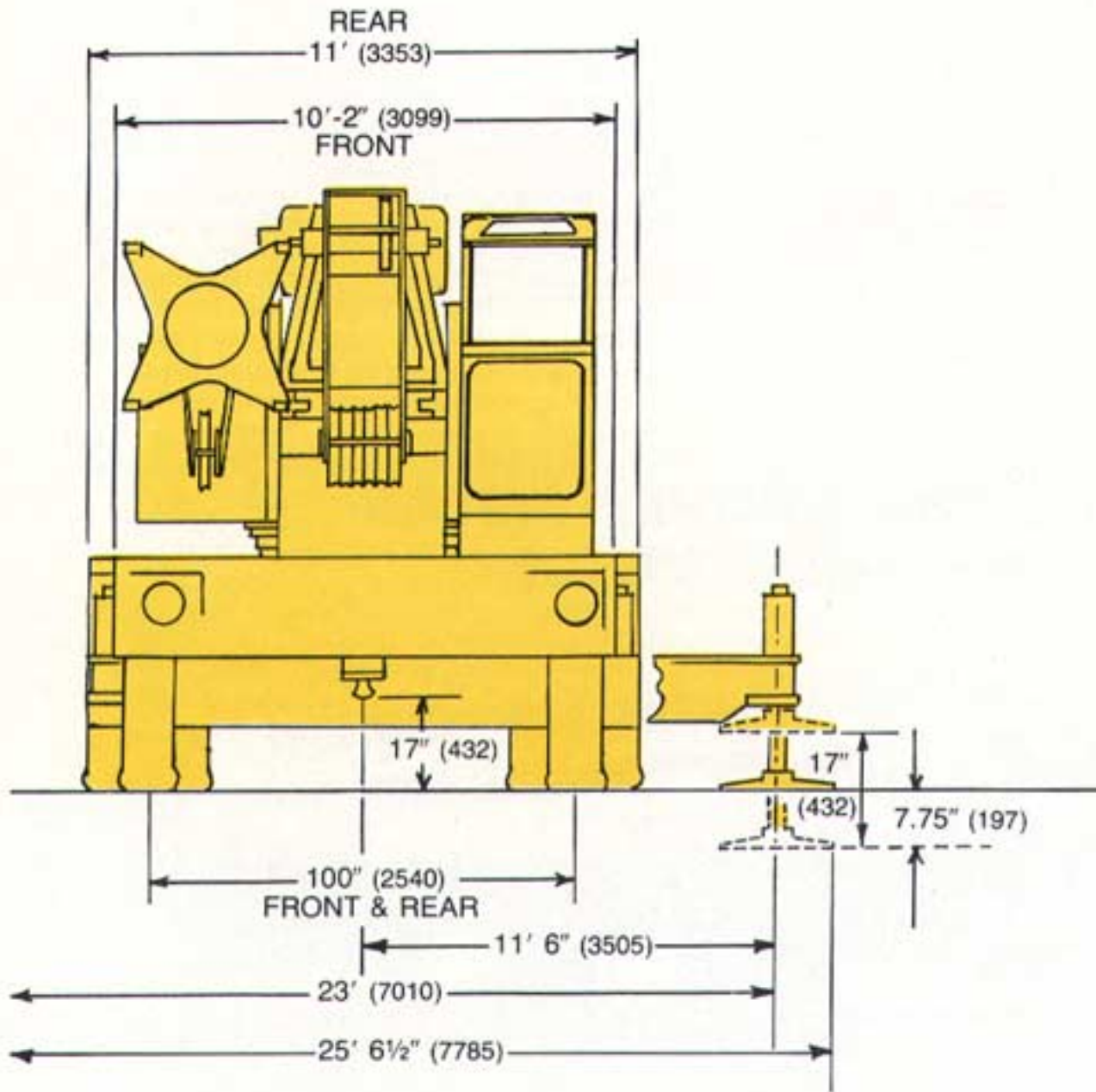

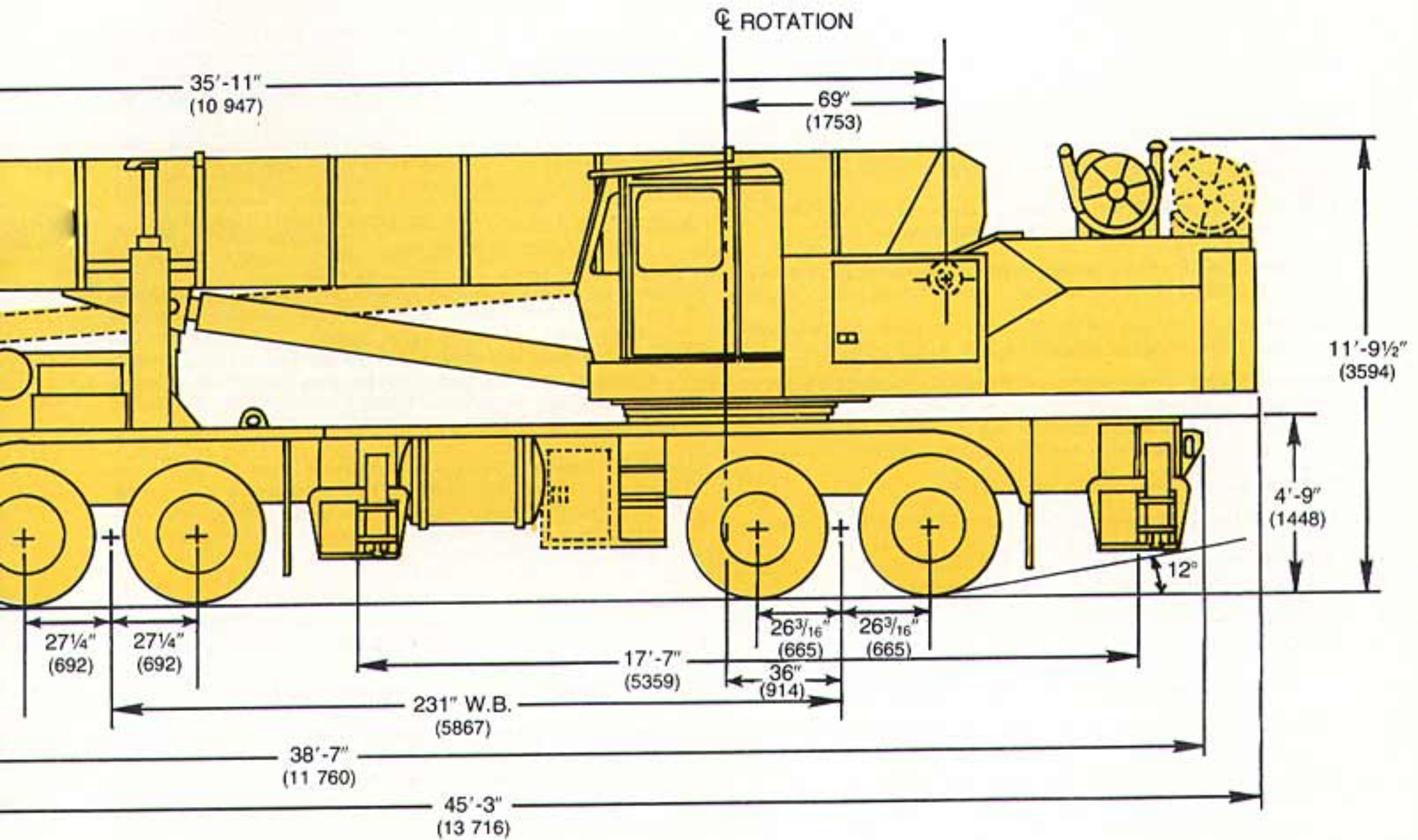

A - Overall height without "A" frame jib - 11' 9½" (3594)  
 Overall height with "A" frame jib - 13' (3962)



## SUPERSTRUCTURE SPECIFICATIONS

**BOOM** – 36 ft. – 146 ft. (11m – 44.5m) total length; 4-section Trapezoidal main boom consisting of base section, 2 full power sections to 88 ft. (26.8m), a power pinned section to 114 ft. (34.8m) and a 32 ft. (9.7m) "Swingaway" lattice boom extension (2° offset).

**\*FULL-POWER BOOM** – 36 ft. – 146 ft. (11m – 44.5m) total length; 4-section Trapezoidal main boom consisting of base section, 3 full power sections to 114 ft. (34.8m) and a 32 ft. (9.7m) "Swingaway" lattice boom extension (2° offset).

Each boom has individually controlled telescope sections supported on graphite impregnated nylatron wear pads. Side adjustable wear pads prevent metal-to-metal contact of inner boom sections and permit ease of boom side alignment. Integral holding valves on each telescoping cylinder [6½ in. (165mm) bore x 26 ft. 1 in. stroke (7950mm)].

**BOOM NOSE** – Five 19.5 in. (495mm) tread diameter sheaves mounted on heavy-duty tapered roller bearings. Removable pin-type rope guards allow easy reeving. Rope dead-ends on each side of boom nose. Six sheaves available for certain international requirements.

Note: 32 ft. (9.7m) "Swingaway" extension has single 19.5 in. (495mm) tread diameter point sheave.

**\*AUXILIARY BOOM NOSE** – Single 19.5 in. (495mm) tread diameter sheave mounted to the main boom nose (removable) for single line work. Removable pin-type rope guards.

**BOOM ELEVATION** – Double-acting 10 in. (254mm) bore x 122 in. (3099mm) stroke hydraulic cylinders with integral holding valves. Elevation from –4 to 80°. Combination controls for hand or foot operation.

**\*LOAD MOMENT AND ANTI-TWO BLOCK SYSTEM (KRUGER)** – Audio-visual warning in combination with Grove control lever lockout of; hoist-up, telescope-out and boom-down crane functions. Kruger LMI control console provides operator with selective display of boom length, radius and angle.

**\*ANTI-TWO BLOCK SYSTEM (KRUGER)** – A separate Kruger anti-two block system can be obtained independent of the complete Kruger LMI system and is available with audio-visual warning only or audio-visual warning in combination with Grove control lever lockout of; hoist-up, telescope-out and boom-down crane functions. The basic system incorporates electronic boom angle indication with high and low angle presets and audio-visual warning. Also available for the system is an electronic boom length indicator. Operator can select between boom length or boom angle display.

**\*JIB** – 28 ft. (8.5m) A-frame jib attaches to the sheave shaft of the 32 ft. (9.7m) lattice "Swingaway" boom extension. Jib stows beneath "Swingaway" extension alongside base boom section or can be detached from "Swingaway" and held firmly in place on base section when extension is used independently. Jib can be offset at 5°, 17° and 30°. Includes jib backstops, single rope self-equalizing suspension, removable pin-type rope guard and 19.5 in. (495mm) tread diameter point sheave.

**\*JIBS** – 14 ft. (4.3m) lattice base section combines with the standard 32 ft. (9.7m) "Swingaway" boom extension to make the basic 46 ft. (14m) jib. Additional 14 ft. (4.3m) pinned inserts available to make 60 ft. (18.3m), 74 ft. (22.6m) and 88 ft. (26.8m) jib lengths. 19.5 in. (495mm) tread diameter jib point sheave mounted on tapered roller bearings. The jib is cable suspended and offset from a minimum of 5° to a maximum of 30°. Jib inserts are not stowable on unit for travel.

**CAB** – Full vision, all-steel, fully enclosed with acoustical treatment, tinted safety glass throughout; windshield, hinged tinted skylight, sliding left side door, sliding right side glass, door and window locks, full adjustable operator's seat with head rest, 20,000 btu diesel fuel heater, electric windshield wiper and defroster fan, swing horn, domelight, dashlight, complete engine instrumentation and crane operating controls, outrigger control panel, adjustable full length control levers, combination hand/foot controls for swing, boom elevation and engine throttle, sight leveling bubble, electronic boom-angle indicator with high/low angle presets and audio-visual warning, 2¼ lb. (1.25kg) dry-type fire extinguisher.

**CAB INSTRUMENTATION** – Engine oil-temperature gauge, engine water-temperature gauge, voltmeter, tachometer, fuel-level gauge.

**SWING** – Roller bearing swing circle, 360° continuous rotation. Grove planetary "glide swing" with foot actuated disc swing brake, spring-set hydraulically released park brake and 360° position positive turntable lock. Combination controls provided for hand or foot operation. Swing speed 1.8 RPM.

**OUTRIGGER CONTROLS** – Independently controlled in-out-up and down, from superstructure cab and either side of carrier frame. Required sequence control arrangement eliminates unintentional outrigger actuation. To insure proper outrigger retraction sequence, front jack cylinder retracts first when master switch is activated from any control station.

**COUNTERWEIGHT** – Fixed position pinned to turntable. \*Power installation and removal system is available. Weight varies depending on hoist configuration. (Refer to axle weight distribution chart.)

### HYDRAULIC SYSTEM:

**RESERVOIR** – 225 gallons (852 liters) all-steel welded construction with internal baffles, cleanout access, exterior oil sight level and temperature gauge.

**FILTER** – Return line type, full flow with bypass protection and filter-bypass indicator, replaceable cartridge. 25 micron rating.

**PUMPS** – Two-tandem main gear pumps driven by carrier engine through PTO with manual declutchable pump drive. Combined capacity 178 GPM (674 lpm) at 2400 RPM.

**CONTROL VALVES** – Precision four-way, double-acting with integral load check, main and circuit relief valves. Four individual valve banks permit simultaneous independent control of four crane functions. Maximum system operating pressure 2500 PSI (175kg/cm<sup>2</sup>).

**OIL COOLER** – Turntable-mounted, full flow, oil to air with thermally controlled hydraulic motor driven fan.

**POWER DISTRIBUTION** – Main hoist, auxiliary hoist boost, \*fly telescope, 51 GPM (193 liters) at 2500 PSI (175.8kg/cm<sup>2</sup>). Main hoist boost, auxiliary hoist, lift boost, inner mid-telescope 51 GPM (193 liters) at 2500 PSI (175.8kg/cm<sup>2</sup>). Lift, outer mid-telescope, 51 GPM (193 liters) at 2500 PSI (175.8kg/cm<sup>2</sup>). Swing, outriggers, 25 GPM (95 liters) at 1500 PSI (105.5kg/cm<sup>2</sup>).

*\*Denotes optional equipment*



## HOIST SPECIFICATIONS

DESCRIPTION: Series parallel circuitry and two motors provide both, high line pull and speed ranges. Power up and down, equal speed, planetary reduction with integral automatic brake and electronic hoist drum rotation indicator.		DESCRIPTION: Power up and down, equal speed, planetary reduction with integral automatic brake and electronic hoist drum rotation indicator.												
HOIST DATA	MAIN HOIST Grove Model 32S-1726B	*AUXILIARY HOIST Grove Model 32S-1716B		*AUXILIARY HOIST Grove Model 15H-16B	*AUXILIARY HOIST (CONTROLLED FREE FALL) Gearmatic Model 23 MGEGR									
Drum Dimensions	16 in. dia. (406mm) 26 in. length (660mm) 24 in. dia. flange (610mm)	16 in. dia. (406mm) 16 in. length (406mm) 24 in. dia. flange (610mm)		12 in. dia. (305mm) 16 in. length (406mm) 17.5 in. dia. flange (445mm)	14.5 in. dia. (368mm) 16 in. length (406mm) 22.3 in. dia. flange (566mm)									
Performance Max. Single Line Speed Max. Single Line Pull	<table style="width: 100%; border-collapse: collapse;"> <tr> <td style="width: 50%;"><b>Hi-Speed Range</b></td> <td style="width: 50%;"><b>Lo-Speed Range</b></td> </tr> <tr> <td>575 FPM (175.3m/min)</td> <td>290 FPM (88.4m/min)</td> </tr> </table>		<b>Hi-Speed Range</b>	<b>Lo-Speed Range</b>	575 FPM (175.3m/min)	290 FPM (88.4m/min)	<table style="width: 100%; border-collapse: collapse;"> <tr> <td style="width: 50%;"><b>Hi-Speed Range</b></td> <td style="width: 50%;"><b>Lo-Speed Range</b></td> </tr> <tr> <td>575 FPM (175.3m/min)</td> <td>290 FPM (88.4m/min)</td> </tr> </table>		<b>Hi-Speed Range</b>	<b>Lo-Speed Range</b>	575 FPM (175.3m/min)	290 FPM (88.4m/min)	383 FPM (116.7m/min) 9,165 lbs. (4157kg)	422 FPM (129m/min) 11,700 lbs. (5307kg)
<b>Hi-Speed Range</b>	<b>Lo-Speed Range</b>													
575 FPM (175.3m/min)	290 FPM (88.4m/min)													
<b>Hi-Speed Range</b>	<b>Lo-Speed Range</b>													
575 FPM (175.3m/min)	290 FPM (88.4m/min)													
Drum Rope Storage Capacity	†1060 ft. of ¾ in. dia. rope max. (323m of 19mm)	†650 ft. of ¾ in. dia. rope max. (198m of 19mm)		†720 ft. of ½ in. dia. rope max. (219.5m of 13mm)	†700 ft. of ¾ in. dia. rope max. (213.4m of 16mm)									
Permissible Single Line Rope Pull (3.5:1 Safety Factor)	¾ in. (19mm) 18x19 class - 14,605 lbs. (6625kg)	¾ in. (19mm) 18x19 class - 14,605 lbs. (6625kg)		½ in. (13mm) 6x37 class - 7,600 lbs. (3447kg) ½ in. (13mm) 19x7 class - 6,150 lbs. (2790kg)	¾ in. (16mm) 6x37 class - 10,200 lbs. (4627kg) ¾ in. (16mm) 19x7 class - 9,600 lbs. (4355kg)									

\*Denotes optional equipment. Auxiliary hoist control valve is standard equipment.  
†Sixth layer of rope not recommended for hoisting operations.

## THREE MODES OF THE GROVE TMS865 "SWINGAWAY"/JIB COMBINATION –



The 32 ft. (9.7m) "Swingaway" and optional 28 ft. (8.5m) A-frame jib can provide the TMS865 with an additional 60 ft. (18.3m) of reach capability, conveniently stowed on the crane. The three different modes of this combination are:

1. Lifting from the main boom with the "Swingaway" extension and jib stowed alongside the base boom section.

2. Lifting from the main boom or "Swingaway" with the "Swingaway" erected and the jib stowed alongside the base boom section.
3. Lifting from the main boom, "Swingaway", or jib with both "Swingaway" and jib erected.

## AXLE WEIGHT DISTRIBUTION CHART

ITEM	POUNDS			KILOGRAMS		
	GROSS	FRONT	REAR	GROSS	FRONT	REAR
Basic standard machine to include 36 ft. – 114 ft. (10.9m – 34.8m) Trapezoidal boom (power-pinned fly) plus a 32 ft. (9.7m) "Swingaway" extension, Grove model 32S-1726B main hoist with 650 ft. of ¾ in. (19mm) rope, 9,000 lbs. (4082kg) counterweight, Grove model 8x4 – 65 carrier, Cummins NTC290 engine with Fuller 9509A transmission, fifth front outrigger jack.	98,464	37,661	60,803	44 664	17 083	27 581
<b>REMOVE:</b>						
•Standard 9,000 lbs. (4082kg) counterweight	-9,000	+4,714	-13,714	-4082	+2138	-6221
Standard 32 ft. "Swingaway" extension	-2,465	-2,286	-179	-1118	-1037	-81
Standard main hoist with rope	-2,832	+1,073	-3,905	-1285	+487	-1771
(2) front outrigger beams and jacks	-3,220	-2,133	-1,087	-1461	-968	-493
(2) rear outrigger beams and jacks	-3,220	+1,310	-4,530	-1461	+594	-2055
<b>ADD:</b>						
65-ton (60 mt) hookblock (stowed)	+1,610	+2,091	-481	+730	+948	-218
28 ft. (8.5m) "A" frame jib (stowed)	+1,582	+1,078	+504	+718	+489	+229
Auxiliary boom head	+230	+409	-179	+104	+186	-81
••Model 15S-16B aux. hoist with 650 ft. (198m) of ½ in. (13mm) dia. rope	+1,055	-531	+1,586	+479	-241	+719
•••Model 23 aux. hoist with 650 ft. (198m) of ¾ in. (16mm) dia. rope	+1,869	-941	+2,810	+848	-427	+1275
••••Model 32S-1716B aux. hoist with 650 ft. (198m) of ¾ in. (19mm) dia. rope and idler	+2,530	-1,274	+3,804	+1148	-578	+1725
Kruger load moment indicator	+376	+136	+240	+171	+62	+109
<b>SUBSTITUTE:</b>						
36 ft. – 114 ft. (10.9m – 34.7m) full power boom	+2,204	+1,002	+1,202	+999	+454	+545
••8,200 lbs. (3720kg) counterweight	-800	+419	-1,219	-363	+190	-553
•••7,730 lbs. (3506kg) counterweight	-1,270	+665	-1,935	-576	+302	-878
••••7,300 lbs. (3311kg) counterweight	-1,700	+870	-2,570	-771	+395	-1166
GM6-71T engine	-500	-517	+17	-227	-235	+8
Cat 3306TA engine	-450	-465	+15	-204	-211	+7

**NOTE:** Appropriate counterweight substitutions must be made depending on main and auxiliary hoist configuration specified.

- Use 9,000 lbs. (4082kg) counterweight without auxiliary hoist.
- Use 8,200 lbs. (3720kg) counterweight with Grove 15S-16B auxiliary hoist.
- Use 7,730 lbs. (3506kg) counterweight with Gearmatic Model 23 auxiliary hoist.
- Use 7,300 lbs. (3311kg) counterweight with Grove Model 32S-1716B auxiliary hoist.

**PROFIT-PRODUCING CYCLE TIMES** begin in the acoustically treated cab where a control arrangement, standardized by Grove, permits maximum efficiency in simultaneous, multi-function operation. With precision and smoothness, the operator commands a high-performance, 4-pump hydraulic system providing all the power necessary for craning operations. The Grove two-speed hoist provides the most productive combination of line speed and line pull for high-cycle work. The speed range is selected by a simple flip of a switch on the cab control panel.

Swing is smooth and precise, powered by a high-torque, low rpm hydraulic motor, with planetary drive and "glideswing."

The Grove TMS865 gives you all of the elements you need for profitable cycle-time production.

# ROADABLE PROFIT-MAKER

**360° OPERATION WITH STANDARD FRONT MOUNTED STABILIZER**

## AUTOMATIC TRANSMISSION\*

Getting there and back is half the fun when you drive this Allison fully automatic transmission. Standard is the Roadranger RT9509A. Both drive through a Fuller two-speed auxiliary.

\*Denotes optional equipment

## CHOICE OF 3 ENGINES

Pick the power plant that best serves your needs. Only Grove gives you this choice.

## 2-SPEED AUXILIARY

## STRONG, RIGID FRAME

for a strong rigid turntable mounting. Outrigger boxes are integral with the frame to provide additional strength and stability.

## 11' WIDE (3.4 m) REAR CHASSIS

## 23' OUTRIGGER SPREAD (7 m)

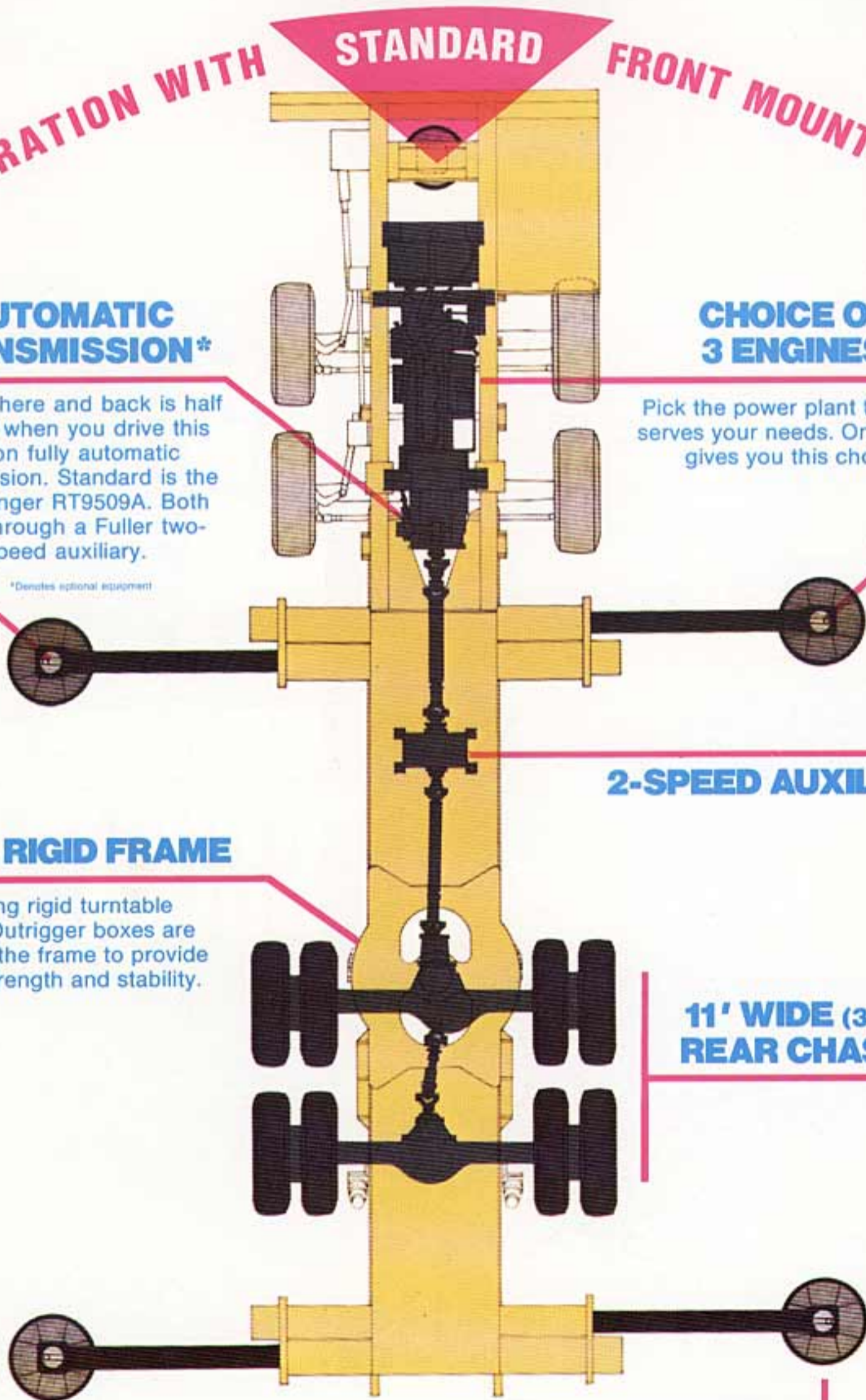

# TMS865

# AM



## GRADEABILITY

On or off the highway, the balanced power-to-weight ratio of the TMS865 will provide the mobility and grade-pulling power that will enable you to move from job to job at highway speeds and around the jobsite with ease.



## HIGHWAY SPEEDS



## TIGHT TURNING RADIUS

In city traffic or tight quarter jobsite locations, the 39' 11" (12.2 m) turning radius will make your job easier.

UNDER

**40'**

# PRODUCTIVE CYCLE TIMES

- LINE SPEEDS UP TO 575 fpm (175.3 m/min)
- SMOOTH, PRECISE SWING
- 4-PUMP RESPONSIVE HYDRAULIC SYSTEM
- EFFICIENT CONTROL ARRANGEMENT FOR MULTI-FUNCTION OPERATION
- UNOBSTRUCTED VISIBILITY

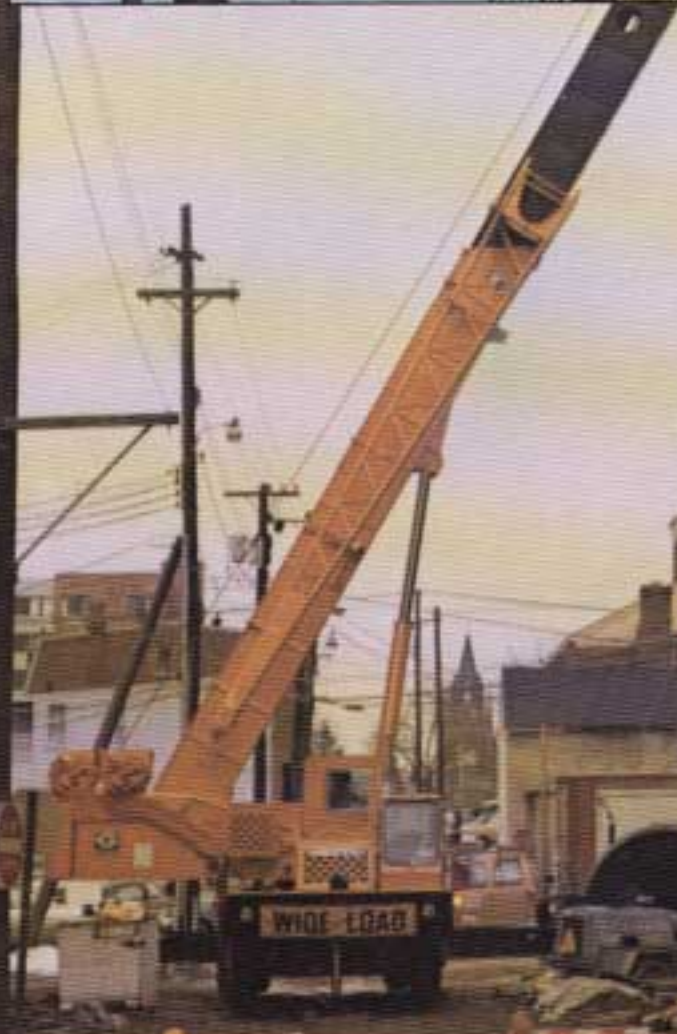

# TMS865

## The 65-Tonner you've been looking for!

ROADABILITY • CAPACITY • REACH • RELIABILITY • PROFITABILITY

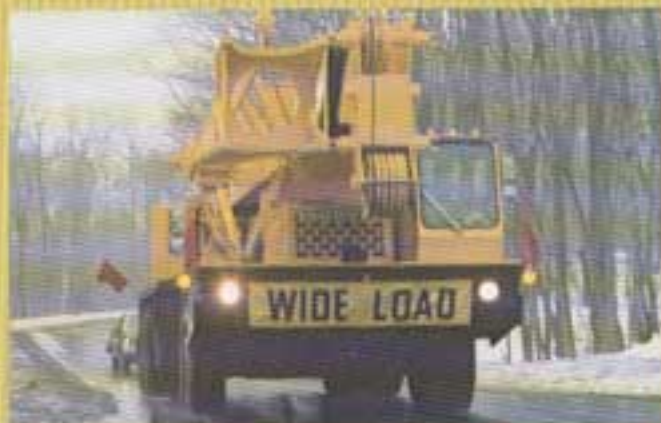

**THE MOST COMPLETE LINE OF  
HYDRAULIC CRANES FOR  
CONSTRUCTION & INDUSTRY**



**CARRIER MOUNTED CRANES**  
18 through 140 U.S. tons  
(18 through 130-tons metric)



**ROUGH  
TERRAIN  
CRANES**  
8 through 80 U.S. tons  
(7.3 through 73-tons metric)



**INDUSTRIAL  
CRANES**  
2 through 35 U.S. tons  
(1.8 through 31.8-tons metric)

WORLD  
LEADER  
IN



**HYDRAULIC  
CRANES**

**GROVE MANUFACTURING COMPANY**

Division of Walter Kidde & Company, Inc.

**KIDDE**

SHADY GROVE, PA. 17256 U.S.A.

Telex: 842308/Cable: GROVEMFG