

# Mobile crane Product advantages

# LTM 1160-5.1

**Max. load capacity: 160 t**  
**Max. height under hook: 95 m**  
**Max. radius: 70 m**



# LIEBHERR

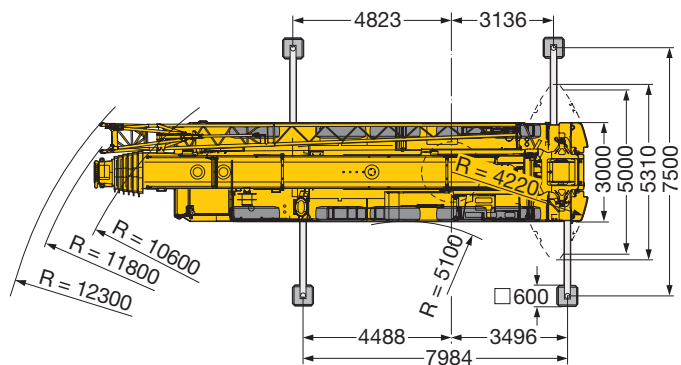
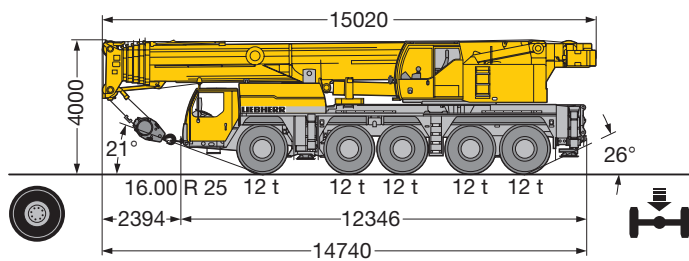

## Compact, maneuverable and weight-optimized

- Overall length 15.02 m, chassis length 12.35 m
- Large overhang angle of up to 26°
- Minimum turning-circle radius 10.6 m with all-wheel steering
- Rear ballast radius only 4.22 m
- 60 t gross weight, incl. 6.5 t ballast, 10 x 8 driveline, 16-inch tires, 26 t hook block (axle load 5 x 12 t)
- 3 optional tire sizes
  - 14.00 R 25 (vehicle width 3 m)
  - 16.00 R 25 (vehicle width 3 m)
  - 20.5 R 25 (vehicle width 3.1 m)

## Modern drive concept

- Powerful, 6-cylinder Liebherr Type D846 A7 turbocharged diesel engine, 370 kW/503 hp, exhaust emissions comply with 97/68/EC Stage 3 and EPA/CARB Tier 3; robust and reliable, with modern, electronic engine management
- ZF AS-TRONIC automated manual shift gearbox; ZF Intarder fitted directly to gearbox; 12 forward and 2 reverse gears, automated gear shift, high number of gear ratios helps to reduce fuel consumption
- Robust 2-stage transfer box with lockable differential, creep speed 0.78 km/h
- Drive 10 x 6: axles 2, 4 and 5 driven
- Drive 10 x 8 (optional): axles 2, 4 and 5 driven, axle 1 can be engaged for off-road travel
- Robust, low-maintenance weight-optimized axles, special arrangement of the maintenance-free suspension control arms for excellent directional and lateral stability, steel and rubber locating bushings
- Maintenance-free propeller shafts; easy and quick fitting due to 70° degree cross-splines
- "Niveumatik" hydropneumatic suspension, program-controlled for raising crane onto outrigger supports, crane travel with equipment and on-road crane travel; suspension travel +150/-150 mm
- Maintenance-free suspension rams free from lateral forces, piston rods protected against damage by plastic tubes
- Retarders:
  - Exhaust brake with additional Liebherr brake system (ZBS), Intarder integrated in gearbox, Telma eddy current brake (optional)
- Service brake:
  - All axles fitted with air-operated disc brakes, high braking performance, extended maintenance intervals, rapid brake pad renewal

## Variable steering concept with „active rear-wheel steering“

Axles 3, 4 and 5 incorporated into active rear-wheel steering system; 5 steering methods can be preselected as fixed programs (P):

### P1: On-road steering

Axles 1 and 2 are steered mechanically from the steering wheel, with hydraulic power assistance. Axles 3, 4 and 5 are steered actively by a speed-dependent method according to the front wheel lock angle. Above 30 km/h, axles 3 and 4 are returned to the straight-ahead position and fixed. Above 60 km/h, axle 5 is also fixed in the straight-ahead position. The change in steering lock angle according to road speed results in precise, stable driving road behavior at higher speeds, reduced tire abrasion and much-improved maneuverability

### P2: All-wheel steering

Axles 3, 4 and 5, depending on the wheel lock angle of axle 1, are turned by means of the steering wheel so that the smallest turning-circle radius can be obtained

### P3: Crabwise steering

Axles 3, 4 and 5 are turned into the same direction as axles 1 and 2 by means of the steering wheel

### P4: Steering without superstructure projection when turning

Axles 3, 4 and 5 are turned in accordance with the wheel lock angle at axle 1, so that the rear of the vehicle does not project when cornering

### P5: Independent rear-axle steering

Axles 1 and 2 are turned by the steering wheel, axles 3, 4 and 5 are steered independent of the lock angle at 1 and 2 by pushbuttons; at the same time the lock angle at axle 3 is adapted to suit the actual situation

- A failure in the rear-axle steering shuts it down; the rear axles are set to the straight-ahead position by centering rams
- Two independent hydraulic circuits with wheel-driven and engine-driven hydraulic pumps for the maximum level of safety
- Two independent control processors (by way of existing input/output modules) and diversified sensor system
- The entire know-how for the active rear-wheel steering comes from Liebherr

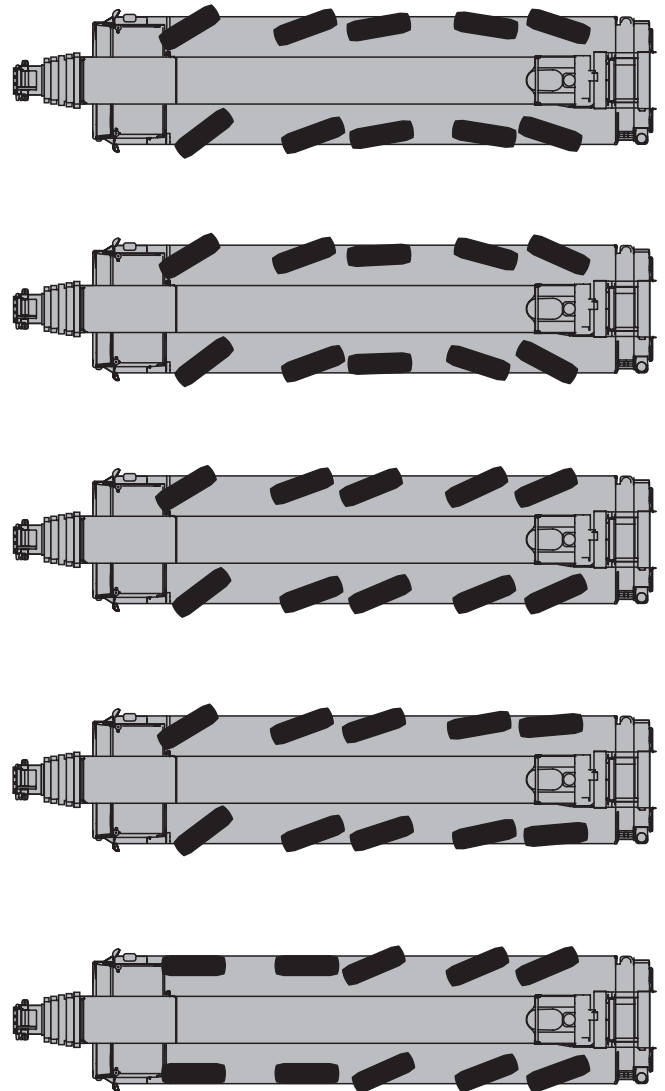

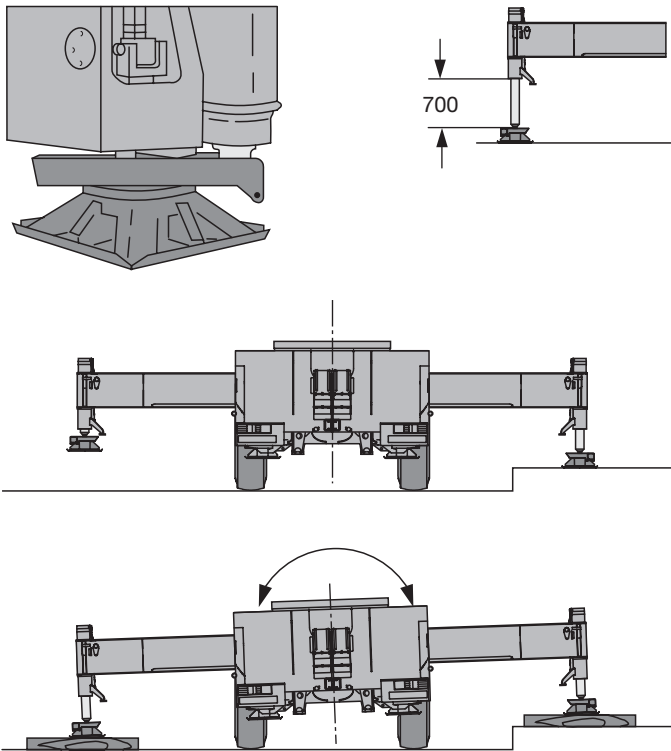

## Supporting crane on outriggers - quick, convenient and safe

- Variable support base width
  - Outriggers retracted
  - Support base area 5.0 m x 7.9 m
  - Support base area 7.5 m x 7.9 m
- Fixed support pads with splash guard for protection against dirt
- Support jack extension range up to 700 mm
- Self-leveling of the outriggers, fully-automatic leveling of the crane by pushbutton during the supporting procedure
- 2 x 9° lateral inclination of crane chassis and superstructure
- Control panels at either side of the chassis with foil-covered keyboard and electronic angle indicator, pushbuttons for ENGINE/START/STOP and speed control are illuminated and lockable
- Operation of the outrigger system in accordance with the accident prevention regulations
- Illumination of the support area by 4 built-in lights



## Comfortable, highly efficient operator's cab

- Modern, comfortable operator's cab of highly efficient, convincing design, corrosion-resistant sheet steel construction, cataphoretic dip-primer coating, resilient rubber front mountings, hydraulic damping at rear, sound and heat absorbent interior paneling
- Safety glass all-round, sunproof green-tinted windshield and side windows for heat absorption, electric window lifters
- Ergonomically correct arrangement of controls and displays for safe and convenient handling for long periods
- Digital display and key-panel units interconnected with the functional blocks by data bus technology
- Air-sprung driver's seat with pneumatic lumbar support and head restraint
- Steering wheel adjustable for height and angle
- Heated, electrically adjustable outside mirrors
- Seat belts for driver and co-driver
- 3 windshield wipers with automatic wipe/wash system and intermittent-wipe setting
- Delayed switch-off of interior lighting
- Various storage shelves and compartments
- Preparation for radio



## Comfortable, highly efficient crane cab

- Crane cab made from corrosion-resistant galvanized sheet steel, powder-coated, with sound and heat absorbent internal paneling, modern interior design, tinted windows all round, opening windshield with large wiper and wipe/wash system, armored-glass skylight with large parallel-action wiper and wipe/wash system, roller sunblinds on windshield and skylight, space-saving sliding door
- Green tinted windshield and side windows for heat absorption
- Pneumatically extending step for safe access to chassis
- Crane cab can be tilted to the rear by 20° to improve view of work area
- 1 work-area light, 70 Watt, at front of the cab
- Sprung, hydraulically damped crane operator's seat with pneumatic lumbar support and head restraint
- Operator-friendly controls integrated into armrests, vertically and horizontally adjustable joystick selector consoles and armrests, ergonomically adjustable operating consoles
- Ergonomically designed control levers with integrated winch rotation and slewing gear feedback device
- Modern instrument panel with integral LICCON monitor, display of all relevant operating data on the LICCON screen
- Preparation for radio





## Crane driveline with field-proven components

- Crane engine: 4-cylinder Liebherr Type D934S A6 turbocharged diesel engine developing 145 kW/197 hp, exhaust emissions in accordance with 97/68/EC Stage 3 and EPA/CARB Tier 3, robust and reliable, located opposite to the crane cab for reduced noise level, electronic engine management, optimized fuel consumption, stainless steel exhaust system
- Hydraulic system with 5 axial-piston variable displacement pumps with servo control and output regulation, electric oil cooler as standard feature
- Standard high-efficient noise insulation for diesel-hydraulic crane drive



## Winch technology by Liebherr

- Winches of Liebherr's own make (hoisting gear 1 and 2) with special rope grooving, built-in planetary gears and spring-action multi-disk hold-on brakes
- Axial-piston constant displacement pumps of Liebherr's own make, specially designed for crane operation and subjected successfully to tough endurance tests
- Display of winch rotation on the LICCON screen
- Low-twist hoisting rope

## Ballasting in a matter of minutes

- High number of ballast variants from 4.6 t - 46.5 t
- Ballasting controlled from the crane cab
- Quick ballasting by the "key-hole" method
- Compact ballast weight dimensions, e.g. only 3 m wide for 32 t of ballast
- Ballast slewing radius only 4.22 m

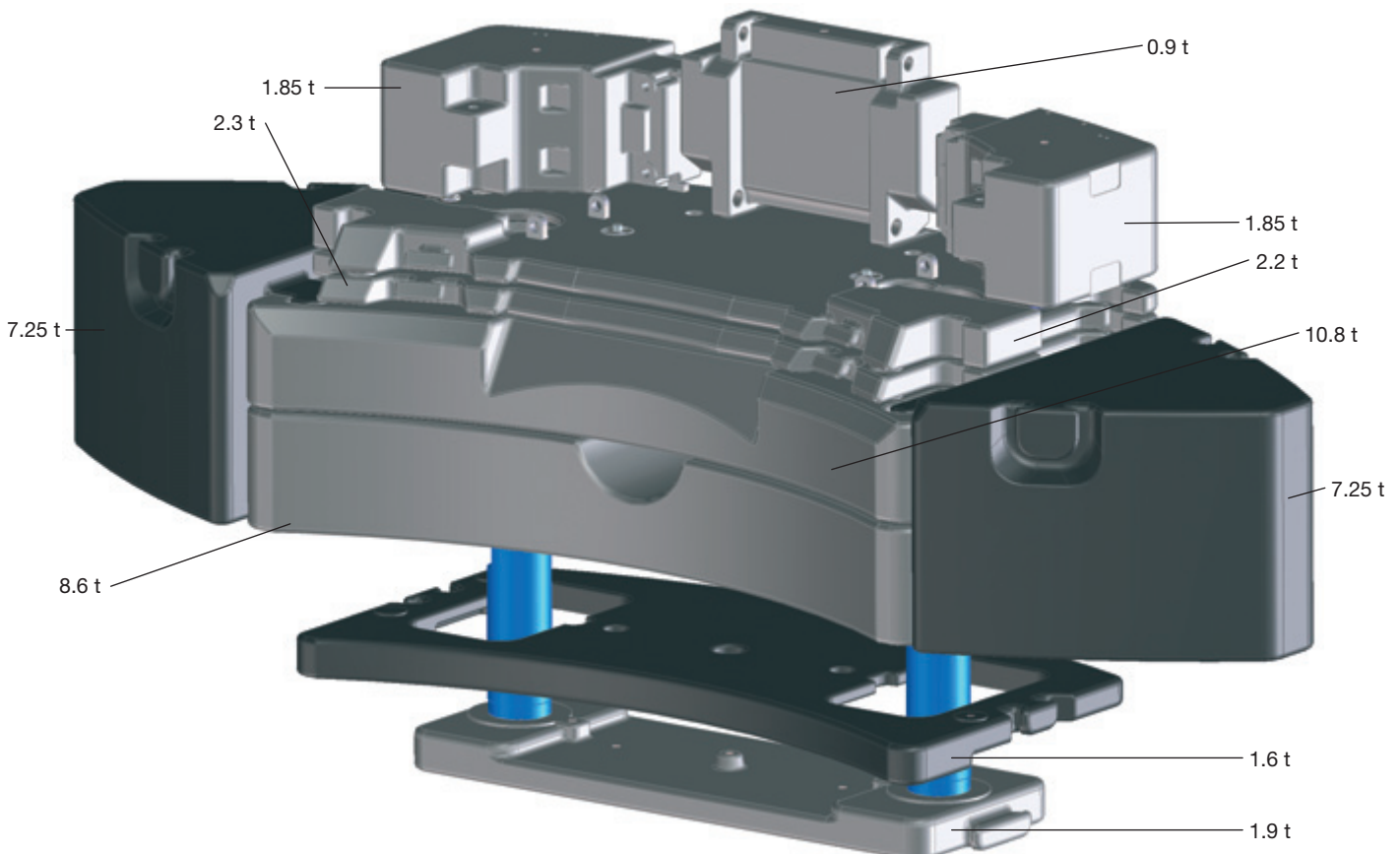

## Lifting loads precisely and safely

- 6-section, 62 m long telescopic boom and 12.2 m - 22 m long double folding jib, can be extended to 29 m or 36 m
- One 7 m long intermediate telescopic boom extension section for operation with folding jib
- Telescopic boom with rounded oval lower chord for high lateral stability
- Optimal utilization of the telescopic boom thanks to a large program of extension variants
- Folding jib can be installed at 0°, 22.5° or 45°; hydraulic erecting aid, hydraulic ram for continuous luffing of folding jib from 0° - 45° (optional)
- Luffing under load (with load interpolation)
- Erecting jib 5.3 m long, integrated into folding jib
- Easy and quick re-reeving of hoisting rope with socket connection
- Load hook with socket connection, cylindrical hook pattern, can be rolled easily for erecting purposes

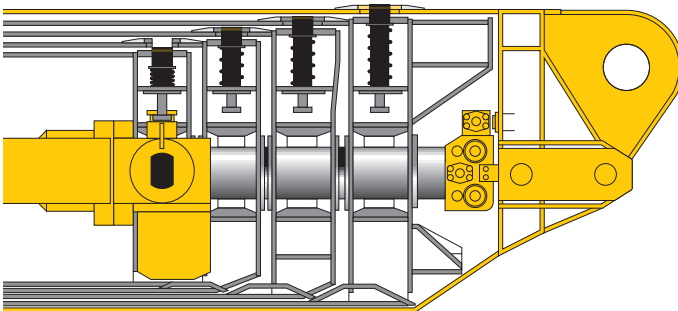

oviform boom profile

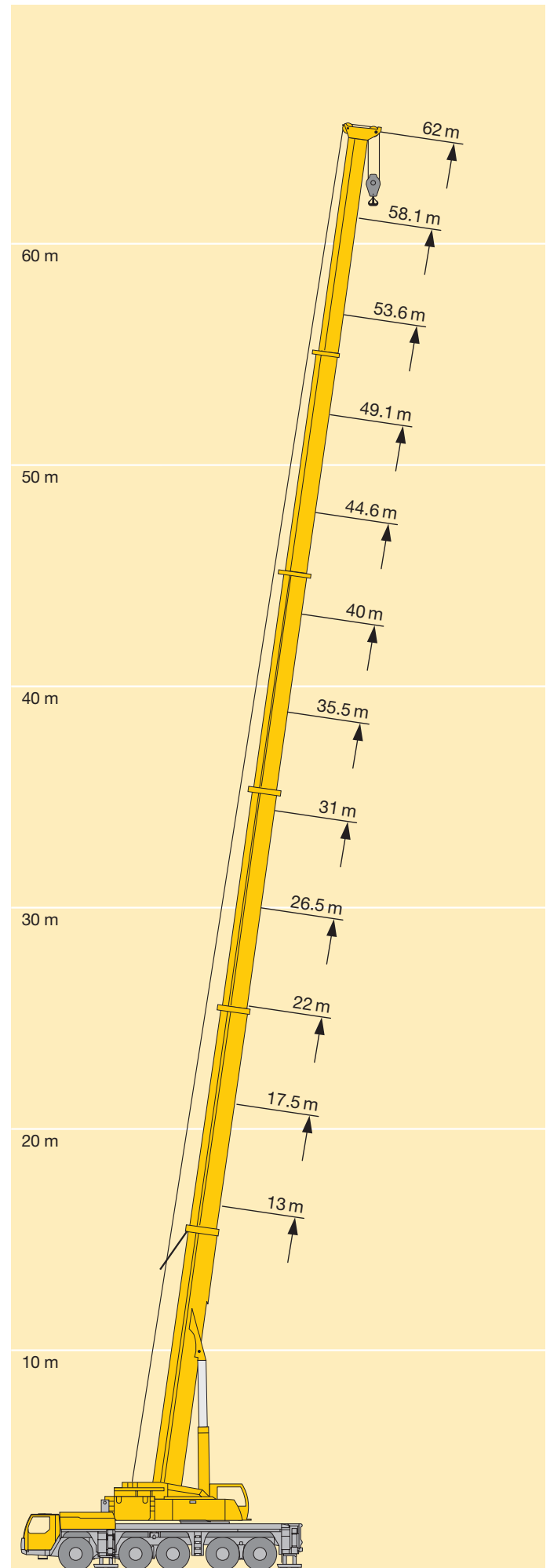
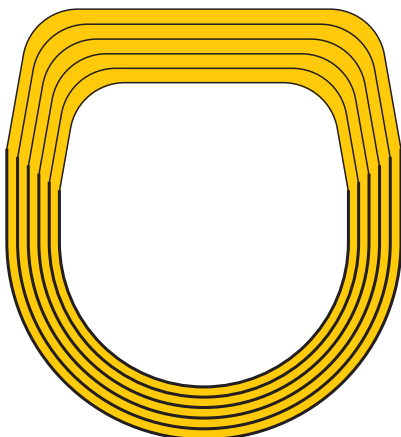

- Electric and electronic components are interconnected by the latest data bus transmission technology
- Instead of the traditional electric wiring, data transmission to the individual function blocks is performed digitally along just a few data cables, thus improving reliability thanks to a much-reduced number of contacts
- Bus systems of Liebherr's own manufacture (LSB), specially suited to mobile crane requirements
- Diesel engine and automatic transmission are controlled by a CAN data bus. All-electronic driveline management reduces fuel consumption and exhaust emissions
- The chassis and crane electrical systems and all cockpit functions and the outrigger and boom sensor systems are interconnected by 4 Liebherr system bus lines
- Control of the function blocks is by I/O modules programmed by the Liebherr system bus lines. The control intelligence is integrated into the central LICCON unit
- Comprehensive diagnostic facilities, quick fault localization, operating error display
- Programs for functional test of keyboard and display unit and for testing the engine and transmission management control units, additional Liebherr brake system, hydraulic fan, hydraulic suspension and outrigger control panels
- This new data bus technology greatly enhances the functionality and efficiency of the mobile crane

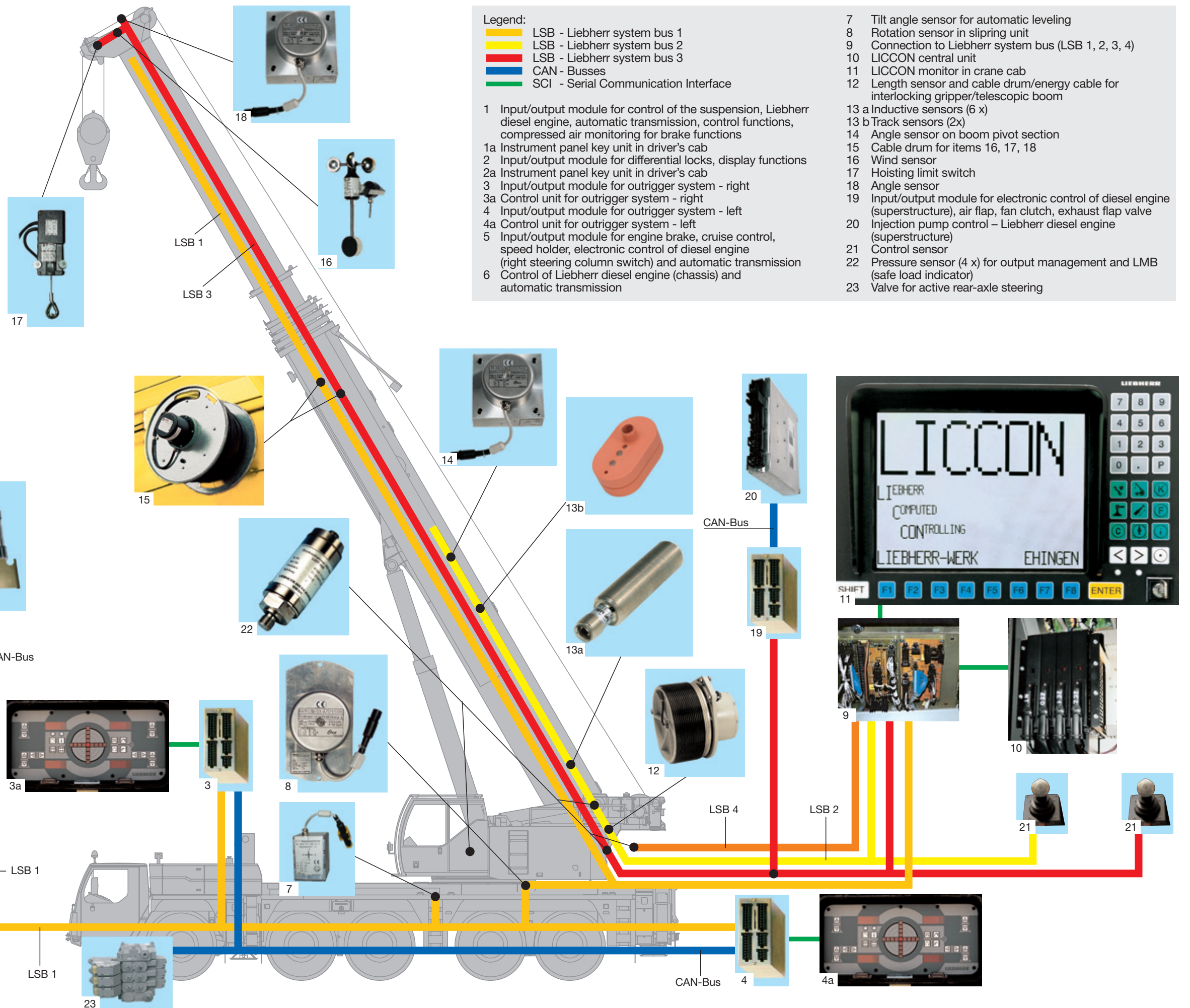



## LICCON setting-up and operating program

- Standard application programs: safe load indicator (LMB), setting-up program with image, operating program with image, telescoping program with image, test parameter program, test system; support load indication and work area limiting as optional features
- Setting-up program values selected by convenient interactive functions
- Safe and reliable acknowledgement of the setting-up values
- All essential data shown by graphic symbols on the operating image
- With integrated wind force measurement
- Reliable shut-down device if admissible load moments are exceeded
- Load capacity values for any intermediate boom length
- Winch displays for precise lifting/lowering of the load

		m > t		CODE>0027<B162 1A00.2(5)					
	m	53,6	53,6	58,1	62,0	17,5	22,0	26,5	
	10,0	15,7	13,8	12,8		30,0	23,7	12,8	
	10,5	15,5	13,6	12,6		30,0	23,7	12,6	
	11,0	15,2	13,3	12,4	10,5	30,0	23,7	12,3	
	12,0	14,7	12,8	12,0	10,3	30,0	23,7	11,9	
	14,0	13,8	11,8	11,3	9,7	27,3	23,7	11,2	
	15,0	13,3	11,3	10,9	9,5	24,8	23,7	10,9	
	16,0	12,8	10,9	10,5	9,2		22,0	10,6	
	18,0	11,9	10,1	9,9	8,7		18,4	10,2	
	19,5	11,3	9,6	9,4	8,3		16,3	10,0	
* n *		* 2 *	* 2 *	* 2 *	* 2 *	* 4 *	* 4 *	* 3 *	
50( 99) <<		▼							>>
	1	92 +	46 +	92 +	100 +	0 +	46 -	92 -	
	2	92 +	92 +	92 +	100 +	46 -	46 -	46 +	
	3	92 +	92 +	92 +	100 +	0 +	0 +	0 +	
	4	92 +	92 +	92 +	100 +	0 +	0 +	0 +	
	5	46 +	92 +	92 +	100 +	0 +	0 +	0 +	
		46.5 t		7.97 x 7.51 m		360°	4x	O.K.	

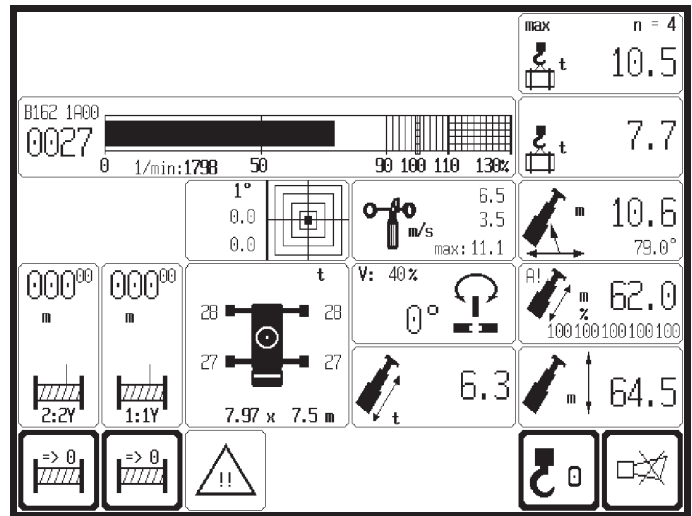

## LICCON-assisted telescoping system

- Telescoping by single-stage hydraulic ram with hydraulic actuating pins (patented internal locking system)
- Telescoping controllable by convenient operator guidance on the monitor screen, precise approach to pin locking positions
- Loads that can be telescoped are shown on the LICCON operating display
- Rapid-cycle telescoping system with automatic mode, i.e. all-automatic telescoping to each desired boom length
- Extremely compact, lightweight telescoping system for increased load capacities, especially with long booms and large radii
- Automatic damping at limit positions during telescoping and retracting, to minimize loads on structural members

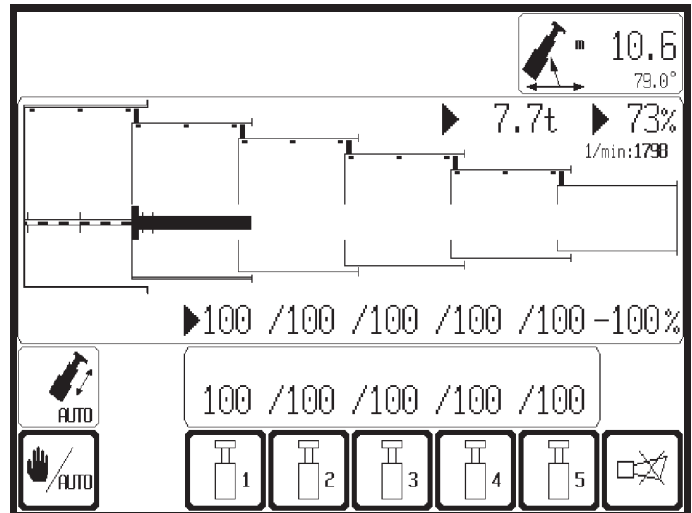

## The LICCON test system

- This test system assists the servicing personnel to localize faults in the crane sensory system quickly without the need for measuring instruments
- Service work starts at the display screen: troubleshooting takes only a few moments
- Faults are indicated by codes and descriptions on the display screen
- Convenient interactive functions permit observation of all inputs and outputs to and from the entire system; they can be displayed in different forms on the display screen even during crane operation. The system also visualizes the position of the system's individual sensors and actuators and their functions

SYSTEM-FUNKTION: AUSGANG		GRUPPE	ZE
A 0.n	DOKUMENTATION	D	I-SOLL I-IST
A 0.0 :	LMB >100%, Ueberbrueckg. - Klingel(D)	1	500 - 520 mA
A 0.1 :	LMB >90%, Vorwahl Klingel (D)	0	0 - 0 mA
A 0.2 :	Pumpe 10 nach TY (D)	0	0 - 20 mA
A 0.3 :	Druckversorgung Hilfsverbraucher (D)	0	0 - 20 mA
A 0.4 :	Drehen Freilauf (D)	0	0 - 0 mA
A 0.5 :	Drehen Bremse (D)	0	0 - 0 mA
A 0.6 :	Drehen rechts (A)	0	0 - 20 mA
A 0.7 :	Drehen links (A)	0	0 - 20 mA

BINFER DEZ/HEX STOP ZURUECK <<==

## The LICCON work area limiting system

- This reduces the crane operator's workload, by monitoring the work area limits, especially in situations where the handling of loads requires close attention. Work areas can be restricted to allow for buildings, bridges, roofs, high-tension power lines, pipelines or adjacent cranes. The automatic work area limiting system (optional) can easily be programmed. Four different limiting functions are practicable:
  - Height limit for pulley head
  - Radius limit
  - Slewing angle limit
  - Border limits

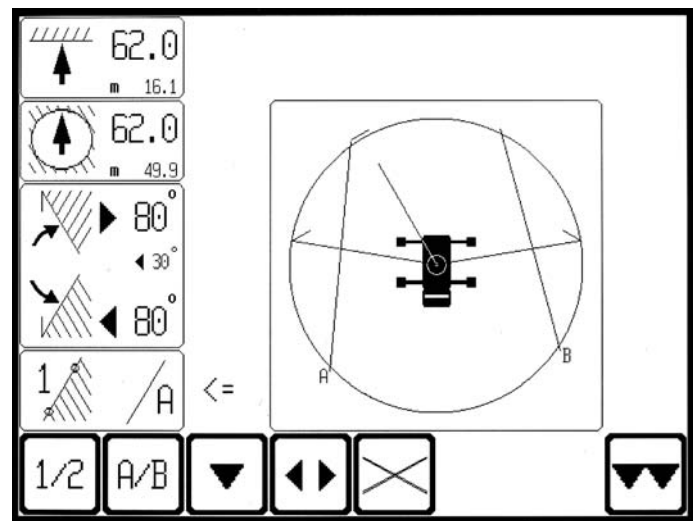

## The LICCON work planner

- The LICCON work planner consists of a software program on CD for the planning, simulation and documentation of crane applications on the display screen (optional)
- The 2D planner program permits buildings to be drawn, text entered and a true to scale crane model represented, including all movements within a simulated construction site
- The work planner creates greater clarity when preparing offers, facilitates the briefing of crane operators and can be run on a laptop at the construction site

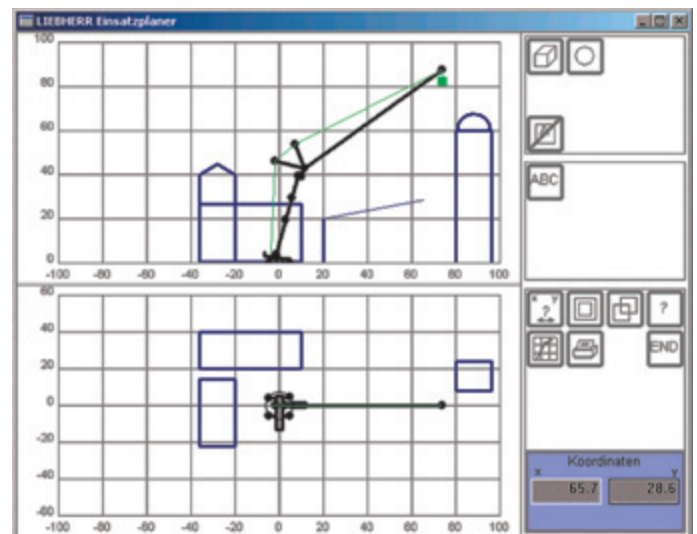

## Electric/electronic PLC crane control with test system

- Control of winches, slewing gear and luffing and telescoping movements by the LICCON computer system (PLC control)
- Four working movements can be performed independently
- 5-step preselection of lifting/lowering, luffing and slewing speeds
- Very rapid response rates when crane movements are selected
- Hoisting and slewing gear run in closed circuits. This permits very sensitive lifting/lowering of loads and slewing movements.

When lowering loads, the energy generated is not converted into heat but can be re-used for a second movement. This saves fuel and the oil is exposed to less heat than when operating in an open circuit

- Functional test of all essential components by means of the LICCON test system

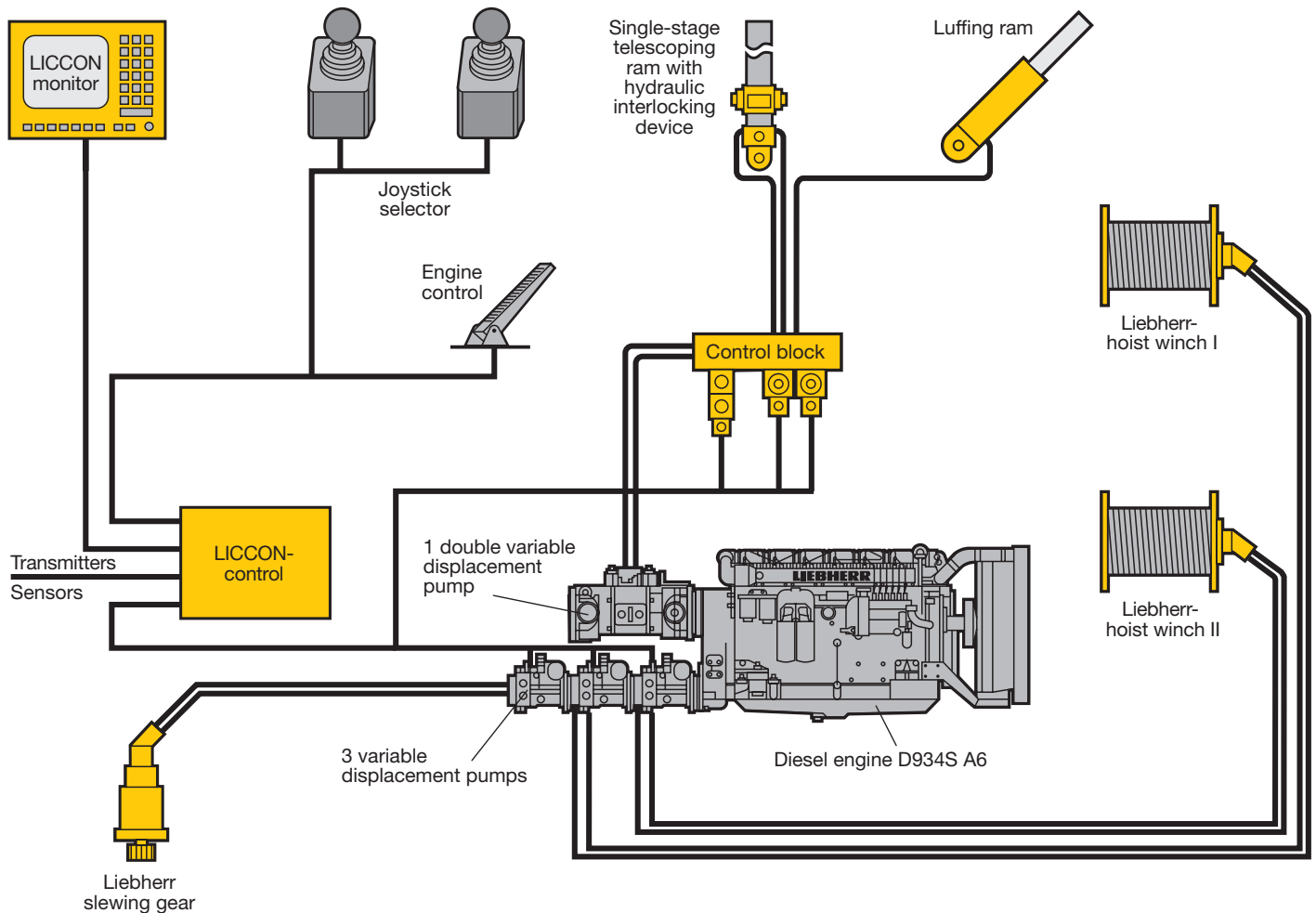

## Optional features make the crane even more versatile and increase operating convenience and safety

On the chassis:

- Additional heater with engine preheating
- Eddy-current brake
- Support load indicator on the chassis and in the operator's cab
- Rope storage box
- Air conditioning
- D12/D19 trailer tow hitch
- Preparation for intercom radio
- Seat heating for driver and co-driver
- Radio with CD player

On the crane superstructure:

- Additional heater with engine preheating
- 2nd hoisting gear
- Air conditioning
- Seat heating
- Work area limiting
- Aircraft warning light
- Xenon work-area light, electrically adjustable, on boom pivot section
- GSM module for tele-diagnostics
- Radio with CD player
- Emergency actuation

Further optional extras on request.